

# Inline beverage analyzers The new generation

## Overview



# Complete your beverage analysis

Beverage manufacturers face a complex variety of operating demands ranging from the need to comply with exacting quality standards and to meet rigorous production schedules to adapting to ever-evolving consumer trends. Global competition and continuously increasing costs require greater production flexibility and efficiency. The key to managing your brand's success lies in improving throughput and quality. To achieve high availability and low operating costs for production facilities, robust and maintenance-free measuring systems are required.

Anton Paar is the leading manufacturer of inline beverage analyzers with custom-made solutions for all beverage applications. These are ready for use without time-consuming on-site adjustment and are fully connected to your laboratory equipment to ensure in-spec production and complete traceability.

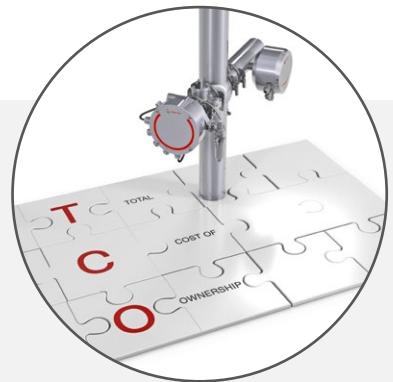

## Keep your operating costs to a minimum

Beverage analyzers are ready to use without time-consuming commissioning and on-site adjustments. Pre-configured in the factory, they come with the right sensor setup and calculation methods for your types of beverages. Equipped with components such as the optical CO<sub>2</sub> sensor, inline pump, inline refractometer, and combined density and sound velocity sensor, they do not require any maintenance; therefore, operating costs are kept to a minimum.



## Seamless quality control under changing conditions

Save time and costs by continuously monitoring your production values. With inline beverage analyzers from Anton Paar, the use of ingredients is optimized, the need for manual measurements is reduced, and out-of-spec products are avoided. Using the best measuring technologies keeps the influence of process variations, such as ingredient batch fluctuations, to a minimum. Rely on drift-free analysis even right after cleaning cycles for faster turn-around times.



## Flexible multiparameter measurement for a wide variety of beverages

Changing preferences among consumers necessitate a universal system for all types of current and future soft drinks, beers, and other alcoholic beverages. Anton Paar's inline beverage analyzers provide the highest accuracy and repeatability on the market for measuring %Diet or TA, and other key parameters such as CO<sub>2</sub>, O<sub>2</sub>, °Brix, sugar inversion, alcohol, and many more.



## Fits your production environment

Installed in both ports of a single VARINLINE® housing and unsusceptible to line vibrations, Anton Paar's inline beverage analyzers are easily fitted in different locations along the production line. The evaluation unit is either built-in or mounted at a nearby, accessible location. Designed according to hygienic and clean-in-place requirements, all models are built for the stable production of soft drinks, diet drinks, beer, wine, cider, FABs, juice, tea, and other beverages.

## Fully connected to your laboratory equipment

The direct connection of process and laboratory analyzing systems supports, automates, and simplifies the calibration and adjustment of Anton Paar's process analyzers with reference results from Anton Paar's lab analyzing systems.



# Inline analysis of beverages

Anton Paar offers a complete range of solutions for beverage analysis.

Our application specialists will find the best system or sensor for your process – the table below gives you a brief overview about the features of the different sensors and systems.



	Cobrix 5500 Beer Monitor 5500 Wine Monitor 5500	Cobrix 5600 Beer Monitor 5600 Wine Monitor 5600	Animo 5100
Sugar concentration	●	●	●
Extract concentration	●	●	●
Alcohol concentration	●	●	●
Sugar inversion compensation	●	●	●
Diet concentration	●*	●*	○
Dissolved CO <sub>2</sub> concentration	●	●	●
Dissolved O <sub>2</sub> concentrationw	○	○	○
Color measurement	○	○	○
8.4" graphic touch panel	●	●	●
Data logging	●	●	●
Data acquisition and visualization interface	●	●	●
HMI on sensor			
Fieldbus connectivity	●	●	●
Maintenance-free		●	○
System engineering and integration			●

● Included as standard

○ Optional

\*Only Cobrix 5500 and 5600

# Inline analysis of beverages



## Cobrix 5500/5600

### Intelligent control solutions for beverage production

The new Cobrix 5500/5600 inline or bypass beverage analyzer provides continuous monitoring of sugared and diet soft drinks, beer, FABs, wine, juice, tea, and other beverages. Depending on the beverage, it measures the °Brix, %Diet or TA, CO<sub>2</sub>, alcohol, sugar inversion, original extract, real extract, and temperature. Control limits are easily set up for individual products and when measured values fall outside their acceptable range, an audible alarm and visual alert are triggered, letting you make the necessary adjustments. Downtime, wasted raw ingredients, and unusable product are all minimized. The new Cobrix 5500/5600 uses a W-shaped oscillating tube and also provides insight into equipment issues by digital signal processing, such as the need for recalibration and periodic maintenance.

### Quick startup

Cobrix 5500/5600 monitors critical quality parameters immediately from the beginning of your production runs. This accelerates startup times, speeds up product changeovers, and reduces the need for laboratory measurements.

### Considerable savings

Cobrix 5500/5600 saves you time and money as it continuously monitors and measures your production values. Syrup yield is optimized, manual measurements are minimized, and out-of-spec values are avoided – all at an exceptionally low cost of ownership and a typical payback of less than one year.

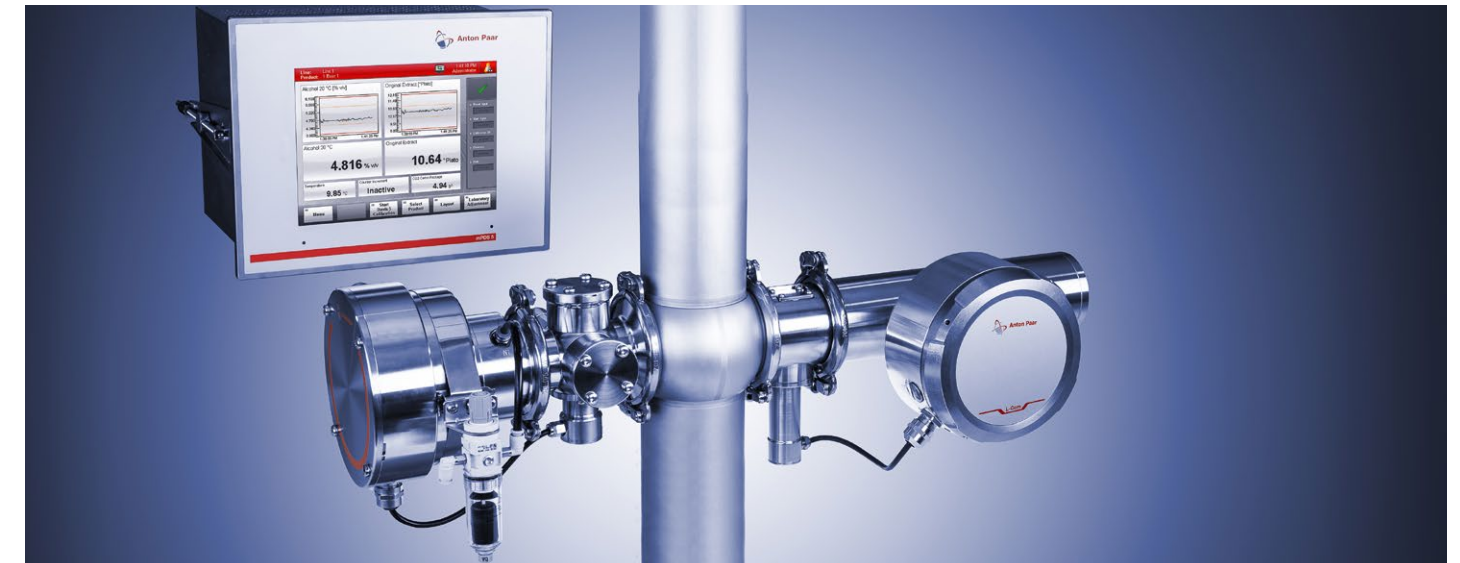

## Beer Monitor 5500/5600

### Inline monitoring of all beer parameters

The new Beer Monitor precisely determines the CO<sub>2</sub>, real and apparent extract, original extract, degree of fermentation, and alcohol content of beer, non-alcoholic beer, and beer mixtures. Measurement values and deviations are shown in real time so you can immediately react to keep the product on-spec and ensure optimal use of raw materials.

### Minimizing your TCO

The Beer Monitor is quickly back to work after CIP/SIP cleaning. You can rely on the maintenance-free, hygienic, and robust Beer Monitor to keep on working for years, minimizing your TCO (total cost of ownership). It uses digital signal processing and a new mechanical design to deliver stable, drift-free results and helps you keep your production running at the highest efficiency level.

**There are two versions of the Cobrix analyzer, Beer Monitor, and Wine Monitor available. Your local Anton Paar representative will help you make the best choice.**

### Cobrix 5500, Beer Monitor 5500 & Wine Monitor 5500:

A density and sound velocity sensor combined with a p/T (volume expansion) CO<sub>2</sub> measurement.

- Low maintenance (maintenance required on average every 6 to 18 months, depending on the operating conditions)
- Product-specific setups at the best value
- New mechanical design for reduced size and weight

### Cobrix 5600, Beer Monitor 5600 & Wine Monitor 5600:

A density and sound velocity sensor combined with an optical CO<sub>2</sub> measurement.

- Product-independent measurement (whatever your beverages' solubility, sugar composition, foreign gases, color, or turbidity: nothing influences your readings).
- Suitable for hygienic applications
- Maintenance-free
- New mechanical design for reduced size and weight

# Inline analysis of beverages



## Alcohol, Brix, and Extract/Plato Monitors can be configured in three different versions:

### Based on density

With L-Dens 7400/7500

- The highest accuracy
- Digital signal processing
- New mechanical design for reduced size and weight
- New Pico 3000 as a transmitter + HMI option
- Suitable for fiscal measurements

### Based on sound velocity

With L-Sonic 5100

- The best value solution
- Digital signal processing
- New Pico 3000 as a transmitter + HMI option
- EHEDG-certified

### Based on refractive index

With L-Rix 5200

- For pulpy and viscous products
- EHEDG-certified

Besides industry-specific custom-tailored inline analyzers, Anton Paar provides a variety of other new inline monitoring solutions. Based on different measurement technologies they can be used throughout the production process according to your requirements and preferences.

## Alcohol Monitor

The Alcohol Monitor determines the alcohol content of binary mixtures (for example numerous spirits or in ethanol production) in the full range of 0 % to 100 %.

### Parameters:

- Alcohol content in %v/v
- Alcohol content in %w/w

## Brix Monitor

The Brix Monitor determines the sugar concentration of soft drinks, fruit juices, and syrups. It masters measurements on products containing all types of sugar (HFCS, cane sugar, beet sugar).

### Parameters:

- Sugar concentration °Brix

## Extract/Original Extract/Plato Monitor

These devices are used in beer production. They allow you to monitor the extract concentration in hot and cold wort (monitor versions based on density, sound velocity, or refractive index) and determine the original extract of your beer (monitor versions based on sound velocity).

### Parameters (depending on the monitor):

- Extract in °Plato
- Original extract in °Plato



## Fermentation Monitor 5100

The Fermentation Monitor continuously monitors the alcoholic fermentation during the production of beer, wine, or spirits based on an inline refractive index measurement.

### Parameters:

- Original extract [°Plato]
- Apparent extract density [°Plato]
- Alcohol [%w/w]
- Alcohol 20 °C [%v/v]
- Real extract [°Plato]
- Real degree of fermentation [%]
- Fermentation speed [alcohol 20 °C increase in %v/v / h]

# Animo 5100: Skid-mounted beer analysis system

Animo 5100 is a modular measuring system which delivers all critical quality control parameters from the beer filling line. It integrates the high-quality online sensors, analyzers, and mechanical components needed for precise and safe operation. Because of its evaluation unit monitoring, operating from a single point and data evaluation from the desktop are easy.

You benefit from a ready-to-go quality control system. Whether a new line is built or an existing line is upgraded with the latest sensor technology – Animo 5100 is individually adaptable to every production environment. The skid dimensions themselves can be custom-fit into the process line. Even the complete implementation of the system without the need of an additional frame is possible. Additional sensors and components can be integrated on request.

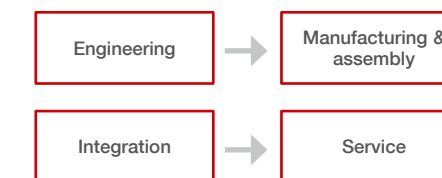
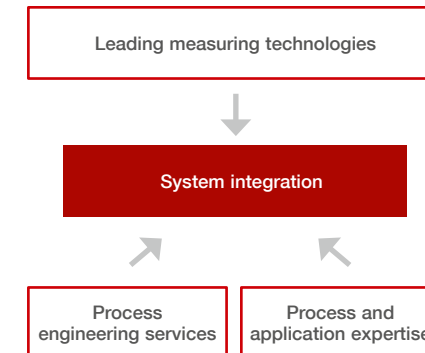
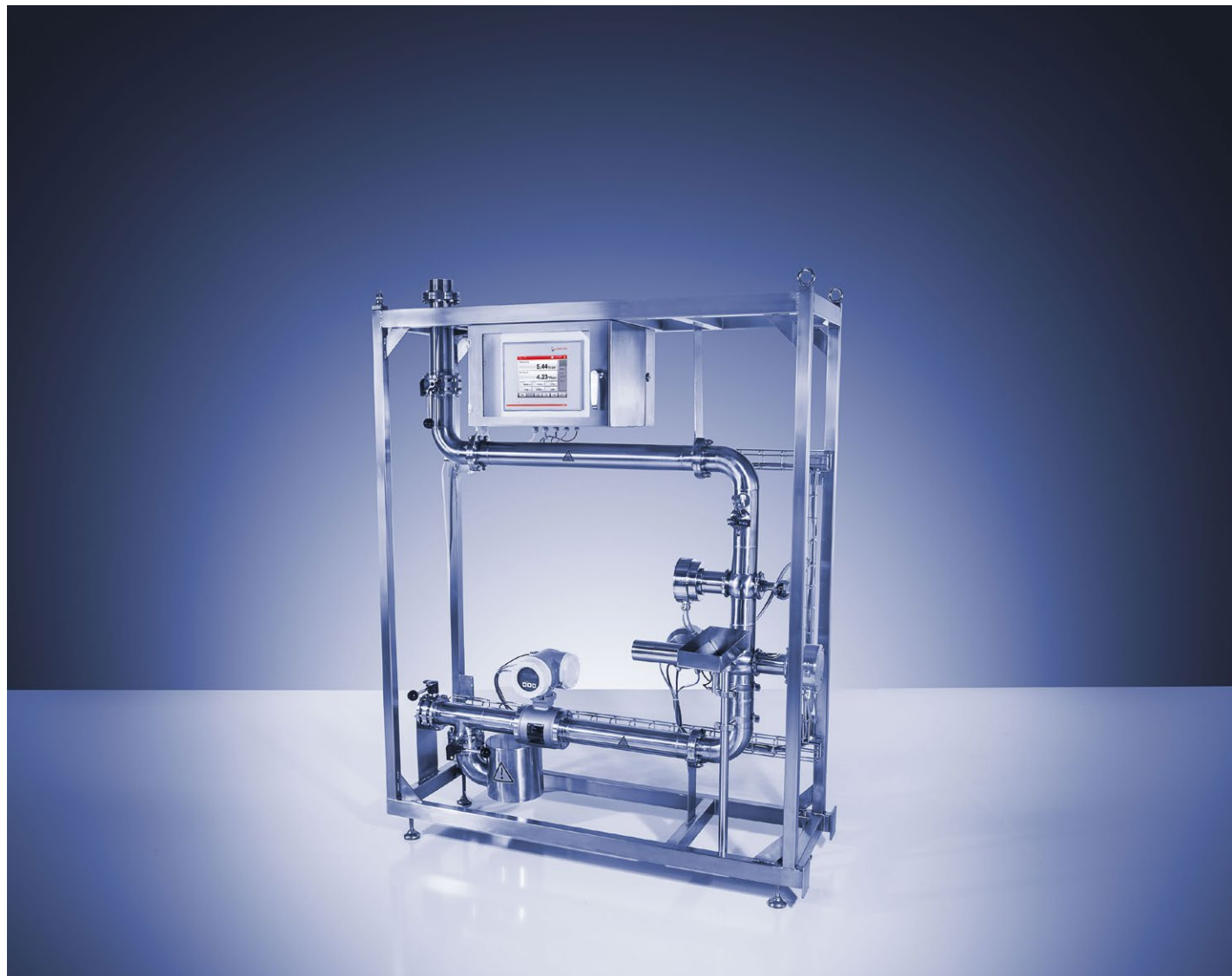

## Systems & integration

Online measurement and analysis in production environments are the basis for efficiently controlling production processes, product distribution, and product quality. Anton Paar combines its leading measuring technologies and application-specific know-how with a complete set of services needed for their integration into your environment and infrastructure. The benefits are best in-class measuring solutions and highly efficient implementation projects.

## Leading measuring technologies in Animo 5100

- L-Com 5500 – a compact sensor for alcohol and extract measurement
- Carbo 520 Optical – the drift- and maintenance-free CO<sub>2</sub> sensor
- Oxy 510 – minimized consumables for dissolved oxygen measurement
- mPDS 5 evaluation unit – process monitoring in real-time
- Davis 5 analysis software – tracing your production quality
- Conductivity sensor – no traces of CIP agents in your products
- Flow meter – cost-effective electromagnetic flow measuring
- Piping and wiring – sanitary piping and hygienic components
- Option: L-Col 6100 – the high-quality and cost-optimized color sensor

## Complete set of services

By providing project engineering, system design, installation support, and commissioning Anton Paar makes the all-in-one package complete.

## Your benefits

- Only 6 weeks from site survey to productive quality control
- One central access point to all critical quality parameters
- Zero out-of-spec products in your packaging line
- No hassles with adjustment and calibration
- Annual maintenance effort: less than one day

# Expand your control capabilities with Davis 5

Davis 5 is Anton Paar's comprehensive data acquisition and visualization software. It can be connected via Ethernet to any personal computer throughout your organization to analyze the production key performance indicators in real time. As Davis 5 connects your lab analyzing systems directly to Anton Paar's inline beverage analyzers, calibration and adjustments are automated and manual operator interaction is no longer required.

## Store and visualize your production data directly from your office desktop

Based on an open client-server architecture, Davis 5 stores production data on your server and enables it to be displayed and accessed simultaneously on multiple PCs throughout your corporate network. Access rights are controlled via the software's integrated user management feature.

Production starts and stops, out-of-range values, trends, statistics, and more can be viewed, downloaded, and printed at any time. Values can be checked, configurations changed, and production stopped directly from the desktop, whenever necessary.

## Protected via product-specific alerts

You can specify production settings, limits, alarms and alerts for individual products. Whenever measured values fall outside the acceptable range, Davis 5 highlights them by changing the screen's background color and sounds an audible alarm so your production team can make the necessary adjustments. Any number of products can be transferred from one production line to another directly from your office desktop. Your created product database can also be transferred to any other production line to be set up with identical product-specific production parameters.

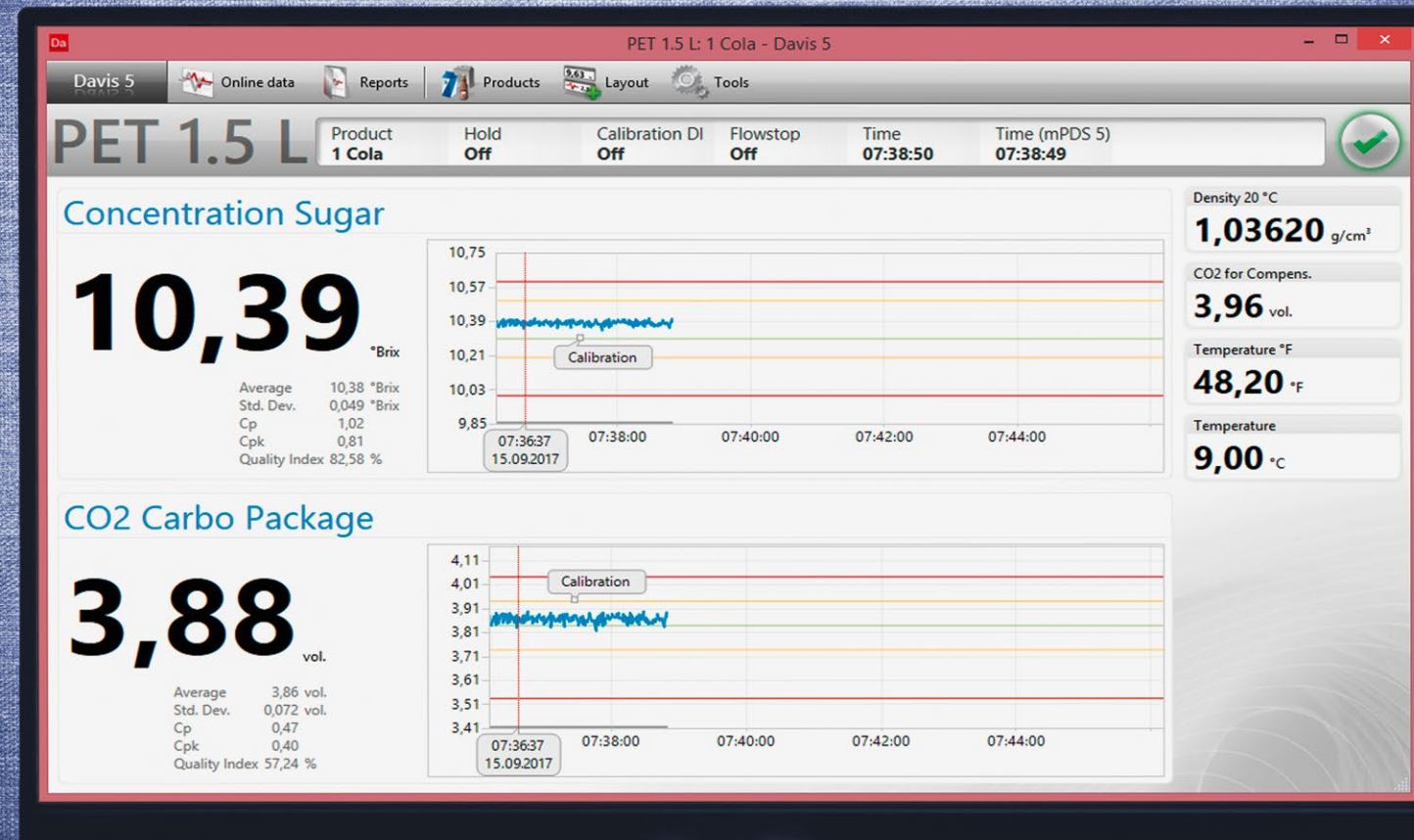

## Calibration and adjustment at the push of a button

By automating the data transfer from the laboratory to the inline beverage analyzers, transcription errors are avoided and the calibration workflow is well-documented.

## Improve your process capability

Production runs can be monitored and analyzed based on process, statistical, and quality data such as the following: Starts and stops, out-of-range values, trends, mean value, min. and max., standard deviation, operating times, line downtimes, bottle and can numbers, history of adjustments, and quality data (Cp, Cpk, and Quality Index, etc.) to fully optimize your processes. You can view initial values while the system continues collecting and storing data.

## Powerful reporting and complete traceability

Davis 5 automates report generation according to your requirements. You can transfer data to LIMS or send e-reports to a smartphone, tablet, or PC. Statistical reports can be viewed in XML or PDF formats to enable readability as part of your corporate quality management system or for integration into other statistical process control (SPC) solutions. The reports are accessible after each batch or at a specific time of the day.

# Inline beverage analyzers in the beer manufacturing process

Your goals are to achieve the highest product quality, to minimize production and maintenance costs, and to react immediately to deviations in the production line. To meet these goals the continuous control and analysis of your process and product are essential. Inline analyzers give you an accurate picture of your process in real time and allow you to optimize your product quality.

Anton Paar's process sensors provide the required transparency at many different measuring points and for critical production steps in the production of beer, soft drinks, and wine.

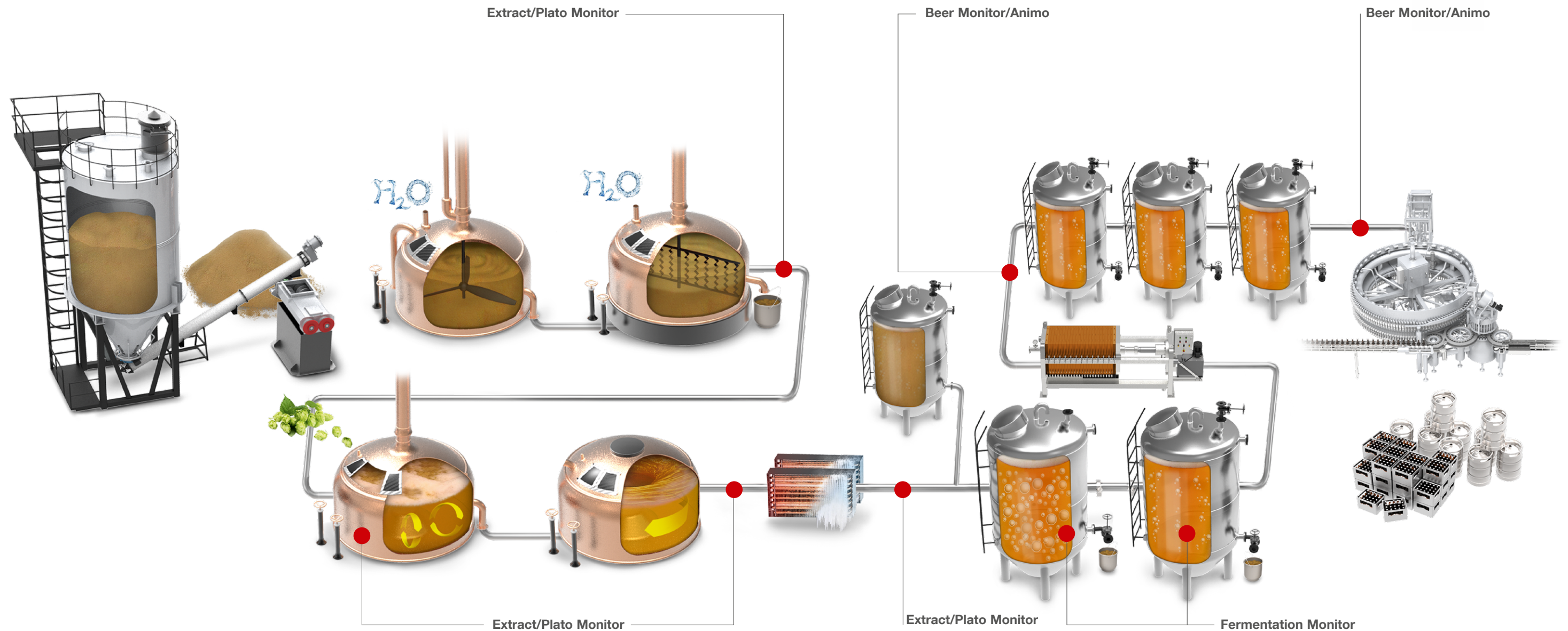



## Inline beverage analyzers in the soft drink manufacturing process

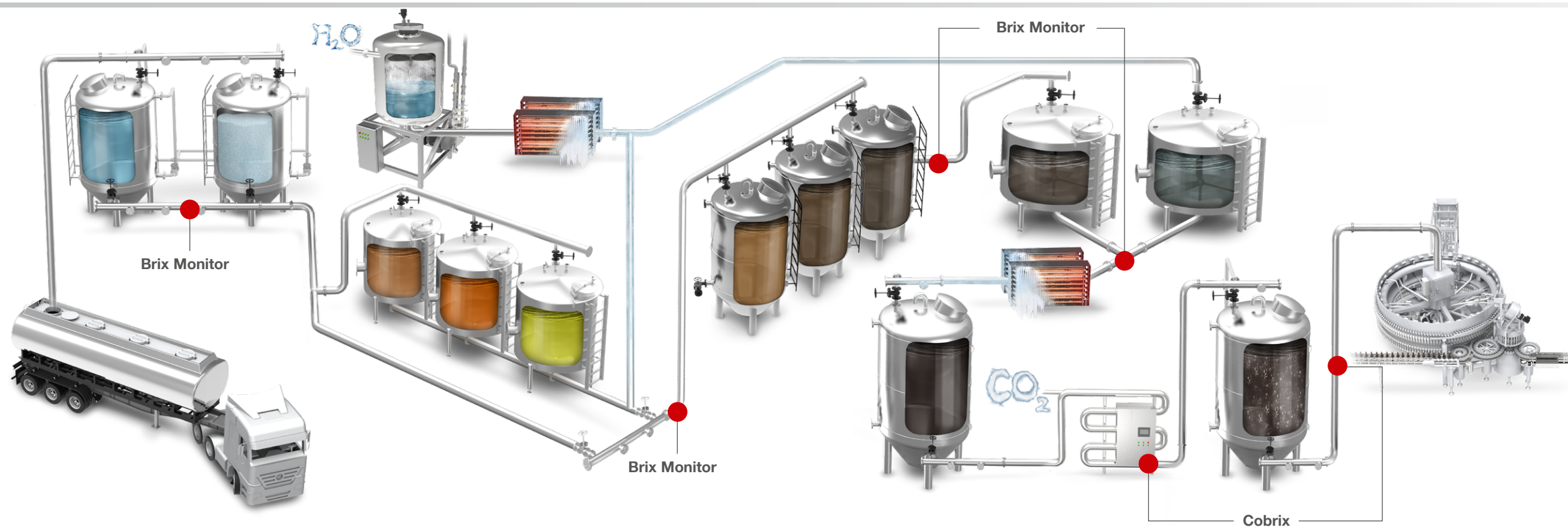

## Inline beverage analyzers in the wine manufacturing process

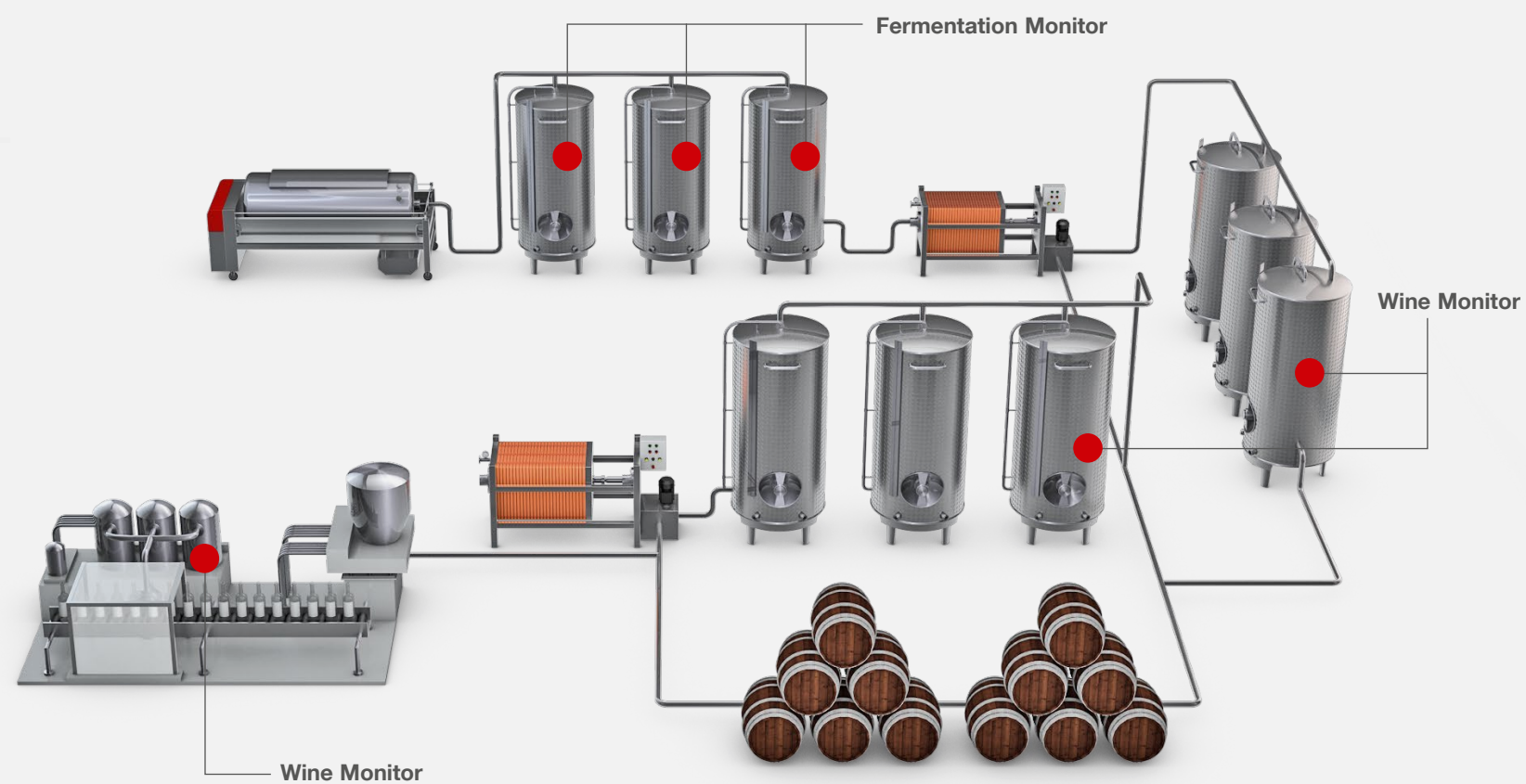

# Technical specifications

Cobrix 5500 and Cobrix 5600	
<b>Sugar/diet concentration</b>	
Range	0 °Brix to 50 °Brix 0 °Brix to 15 °Brix for products with sugar inversion 0 % to 150 %Diet of target
Accuracy	Sugared drinks: <0.02 °Brix Diet drinks: <1 %
<b>CO<sub>2</sub> concentration</b>	
Range	0 Volumes to 6 Volumes 0 g/L to 12 g/L
Accuracy	0.025 Vol. (0.05 g/L)
<b>FABs (alcopops)</b>	
Alcohol range	0 %w/w to 16 %w/w (%weight/weight) 0 %v/v to 20 %v/v (%volume/volume at 20 °C)
Alcohol accuracy	0.02 %w/w
<b>Measuring temperature</b>	
	0 °C to 30 °C 0 °C to 25 °C for products with sugar inversion, diet beverages, and FABs

Beer Monitor 5500 and Beer Monitor 5600	
<b>Real extract</b>	
Range	0 °Plato to 12 °Plato
<b>Original extract</b>	
Range	0 °Plato to 35 °Plato
<b>Real/original extract</b>	
Accuracy	0.02/ 0.04 °Plato
<b>CO<sub>2</sub> concentration</b>	
Range	0 Volumes to 6 Volumes 0 g/L to 12 g/L
Accuracy	0.025 Vol. (0.05 g/L)
<b>Alcohol</b>	
Range	0 %w/w to 12 %w/w (%weight/weight) 0 %v/v to 15 %v/v (%volume/volume at 20 °C)
Accuracy	0.02 % v/v
Measuring temperature	-3 °C to 25 °C

Wine Monitor 5500 and Wine Monitor 5600	
<b>Extract</b>	
Range	0 %w/w to 10 %w/w
Accuracy	0.04 %w/w
<b>CO<sub>2</sub> concentration</b>	
Range	0 Volumes to 6 Volumes 0 g/L to 12 g/L
Accuracy	0.025 Vol. (0.05 g/L)
<b>Alcohol</b>	
Range	0 %w/w to 16 %w/w (%weight/weight) 0 %v/v to 20 %v/v (%volume/volume at 20 °C)
Accuracy	0.02 %v/v
Measuring temperature	0 °C to 25 °C

Animo 5100		
Parameter	Range	Accuracy
Alcohol	0 ... 12 %w/w; 0 ... 15 %v/v	±0.02
Real extract	0 ... 12 °Plato	±0.02 °Plato
Original extract	0 ... 35 °Plato	±0.04 °Plato
Dissolved CO <sub>2</sub> concentration	0 Volumes to 6 Volumes 0 g/L to 12 g/L	0.025 Volumes 0.05 g/L
Conductivity	Range (adjustable): <10 mS/cm; 10...100 mS/cm; 100...999 mS/cm	Resolution: 1 µS/cm; 10 µS/cm; 100 µS/cm
Temperature measurement	-3 ... +145 °C	±0.1 °C
Pressure measurement	0 ... 16 bar absolute	±0.1 bar
Flow	v = 0.01 ... 10 m/s with the specified measuring accuracy	±0.5 % of reading ±1 mm/s
Color (option)	0 ... 30/150 EBC (depending on optical path length)	Reproducibility: ±1% transmissstion

Alcohol Monitor	Based on density	Based on sound velocity	Based on refractive index
Range	0 %v/v to 100 %v/v or %w/w	50 %w/w to 100 %w/w	0 %w/w to 40 %w/w
Accuracy	0.05 %w/w (0 % to 90 %) 0.03 %w/w (90 % to 100 %)	0.1 %w/w	0.23 %w/w
Measuring temperature	0 °C to 40 °C	10 °C to 50 °C	10 °C to 50 °C

Brix Monitor	Based on density	Based on sound velocity	Based on refractive index
Range	0 °Brix to 70 °Brix	0 °Brix to 35 °Brix	0 °Brix to 100 °Brix (0 °Brix to 15 °Brix)
Accuracy	0.025 °Brix	0.06 °Brix	0.1 °Brix (0.05 °Brix)
Measuring temperature	0 °C to 100 °C	-3 °C to 105 °C	0 °C to 100 °C (3 °C to 25 °C)

Extract/Plato Monitor	Based on density	Based on sound velocity	Based on refractive index
Range	0 °Plato to 70 °Plato	0 °Plato to 35 °Plato	0 °Plato to 100 °Plato (0 °Plato to 15 °Plato)
Accuracy	0.025 °Plato	0.06 °Plato	0.1 °Plato (0.05 °Plato)
Measuring temperature	0 °C to 100 °C	-3 °C to 105 °C	0 °C to 100 °C (3 °C to 25 °C)

Fermentation Monitor 5100	
<b>Refractive index</b>	
Range	0 °Plato to 30 °Plato
Accuracy	0.1 °Plato
Process temperature	-20 °C to 100 °C   CIP/SIP up to 145 °C for 30 min

CIP/SIP	
5500 models	120//121 °C for max. 30 min CIP
5600 models	95 °C for max. 4h CIP
Fermentation Monitor	145 °C for max 30 min SIP/CIP

General specifications	
Line pressure	max. 10 bar (145 psi)
Degree of protection	IP65 (sensors), IP54 (mPDS 5 evaluation unit)
Power supply	SELV 24 VDC
Power consumption	100 W
mPDS 5 fieldbus boards	PROFIBUS DP, PROFINET IO, EtherNet/IP, Modbus TCP, DeviceNet

